

**PROEND GRIP** is a non-slip step nosing profile in anodized aluminium with adhesive non-slip 20mm thick insert in black carborundum to be fitted in the relative groove in the top of the profile upon completion of laying. The profile may be laid with fixing screws hidden afterwards by the adhesive carborundum, or with silicone and/or adhesive to be applied on the bottom of the profile, which is designed to ensure an excellent grip. It is made in anodized aluminium with silver, gold or bronze finish with anodizing coat of approx. 15/20 micron.

# PROEND GRIP

SILVER, GOLD AND BRONZE ANOD. ALUMINIUM  
+ NON-SLIP INSERT ADHESIVE AND PUNCHED



ANODIZED SILVER, GOLD AND BRONZE ALUM. with adhesive thermo packed - bar length 2,7 lm - pack. 20 Pcs - 54 lm

Article	H x L mm
PEGR... 5230A	30 X 52

On demand bar length 3 lm with minimum quantity of 200 pcs. Production delay 4/5 weeks. Price to be agreed.

ANODIZED SILVER, GOLD AND BRONZE ALUM. with adhesive - thermo packed bar length 1,66 lm - pack. 20 Pcs



Article	H x L mm
PEGR... 523016AS	30 X 52



ANODIZED SILVER, GOLD AND BRONZE ALUM. punched thermo packed - bar length 2,7 lm - pack. 20 Pcs - 54 lm

Article	H x L mm
PEGR... 5230F	30 X 52

ANODIZED SILVER, GOLD AND BRONZE ALUM. punched, screws and screw anchors - thermo packed bar length 1,66 lm - Pack 20 Pcs



Article	H x L mm
PEGR... 523016FS	30 X 52

Available in the finishes: AA - AO - AB.

The code of the selected finish must be added to the article code. E.g.: PEGR... 523016AS (chosen finish anodized silver) PEGRAA 523016AS.

The adhesive carborundum strip (PROGRIP) is not included with the profile.  
For PEGR... 5230... order PGR... 20 (Specify the chosen colour).

## COLOURS



\* = Production on demand with minimum quantity of 100 pcs. Production delay 4/5 weeks. Price to be agreed

**PROGRIP** is a self-adhesive product in carborundum consisting of a plastic film plus abrasive granules with high resistance to wear. It is normally used to guarantee safety on steps in public and private environments, as required by accident-prevention laws. Available in various colours and widths to meet all technical and aesthetic requirements. It is advisable to apply 2 strips on each step, rounding off the ends.

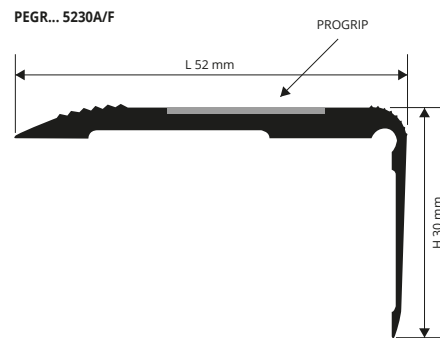

stair nosing for existing steps

## EXAMPLES AND INSTRUCTIONS FOR LAYING METHODS

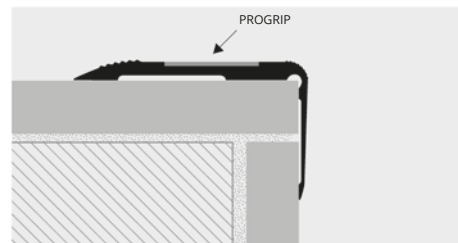

1. Choose the suitable profile for covering the edge of the step.
  2. Clean the surface on which the profile is to be laid, ensuring that it is grease-free and dry. Do not apply the strips at temperatures below 15°.
  3. Remove the protective paper from the adhesive and lay correctly by applying pressure evenly over the whole profile without using a hammer.
- If the punched PROEND GRIP has been chosen, screw the profile to the step and apply the adhesive carborundum to hide the screws.

# PROGRIP

ADHESIVE CARBORUNDUM - 6 COLOURS



## COLOURS

N - Black	B - White	T - Transparent
G - Gray	Y - Yellow	M - Brown
GN - Yellow/Black	The PGRT (transparent) are not suitable for outside use.	

## ADHESIVE CARBORUNDUM NON-SLIP STRIP for STEPS

rolls length 18,2 lm

Article	Width mm
PGRN 20	20
PGRB 20	20
PGRT 20	20
PGRG 20	20
PGRY 20	20
PGRM 20	20
PGRN 25	25
PGRB 25	25
PGRT 25	25
PGRG 25	25
PGRY 25	25
PGRM 25	25
PGRN 50	50
PGRB 50	50
PGRT 50	50
PGRG 50	50
PGRY 50	50
PGRM 50	50

## ADHESIVE NON-SLIP STRIP for STEPS - rolls length 18,2 lm

Article	Width mm
PGRGN 20	20
PGRGN 25	25
PGRGN 50	50



non-slip strip for steps

## LAYING INSTRUCTIONS

1. Thoroughly clean and degrease the surface of application.
2. Round the ends of the strips.
3. Remove the protective paper from the adhesive and lay the PROGRIP using a roller.
4. Do not apply the strips at temperatures below 15°; otherwise heat the strips and the step.
5. When necessary clean away impurities with a brush and preserve the PROGRIP.
6. When laying on tiles, cut and round the corners of the strips on the inner part of the tile.
7. Carefully seal the outer edges of the strips to prevent water infiltration.