

GAP-COVERING BALLOON SHEATH

COEXTRUDED FLEXIBLE VINYL RESIN

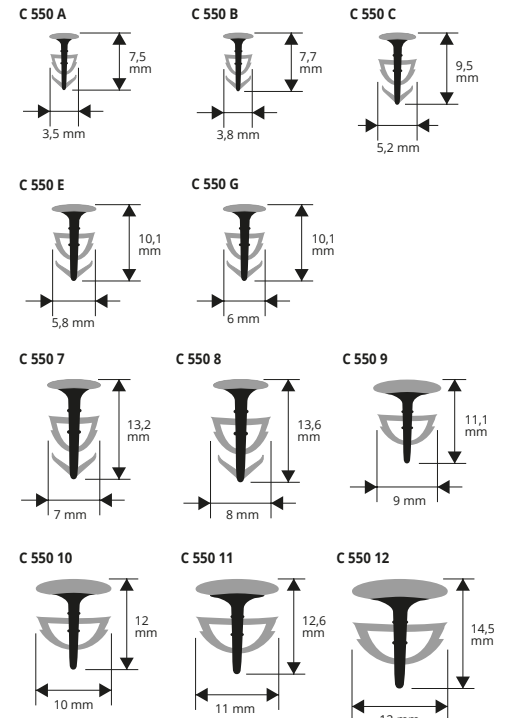
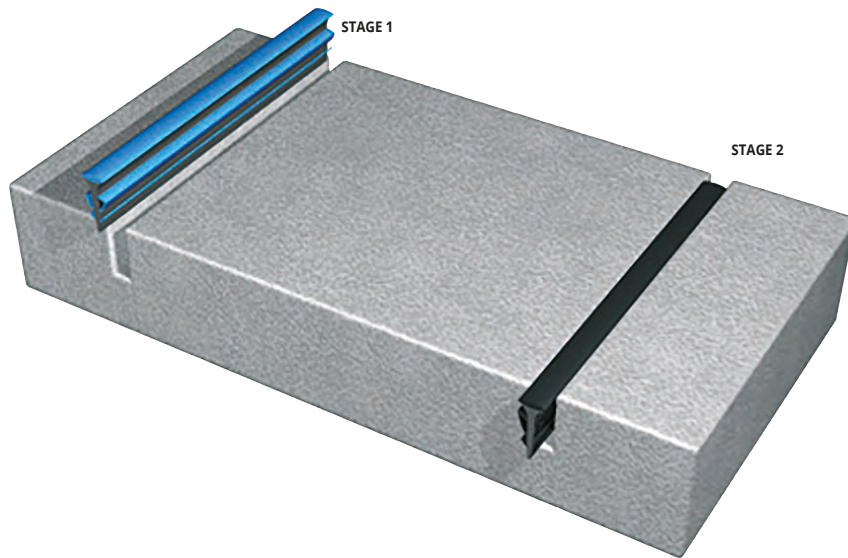

For industrial floors - FLEXIBLE VINYL RESIN

pack. roll 250 lm

Article	sheath L mm	disk thick mm		
C 550 A..	3,5	2,4		*
C 550 B..	3,8	2,8		*
C 550 C..	5,2	3,2		*
C 550 E..	5,8	3,6/3,8		*
C 550 G..	6	4,2		*

MINIMUM QUANTITY 20 ROLLS = 5000 lm per colour and dimension.
Available for every type of diamond and abrasive disk.

For larger gaps - FLEXIBLE VINYL RESIN

pack. roll 200 lm

Article	sheath L mm	disk thick mm		
C 550 7..	7	5/6		*
C 550 8..	8	6/7		*

For larger gaps - FLEXIBLE VINYL RESIN

pack. roll 150 lm

Article	sheath L mm	disk thick mm		
C 550 9..	9	7/8		*
C 550 10..	10	8/9		*

For larger gaps - FLEXIBLE VINYL RESIN

pack. roll 100 lm

Article	sheath L mm	disk thick mm		
C 550 11..	11	9/10		*
C 550 12..	12	10/11		*

Available in the colours: G - Y - R - N - B. The code of the selected colour must be added to the article code. E.g.: C 550 A.. (chosen colour Grey) C 550 AG.

COLOURS



RESOLVES THE FOLLOWING PROBLEMS:

- Perfectly covers the gap made with any type of disk and remains for a long time at floor level without sinking.
- Thanks to the central semi-rigid shank, the sheath cannot contract in the joint areas.
- When the disk is worn, the sheath need not be changed because it adapts to even the narrowest gaps.
- Also available for larger gaps from 6 mm to 12 mm.
- Very easy to lay.

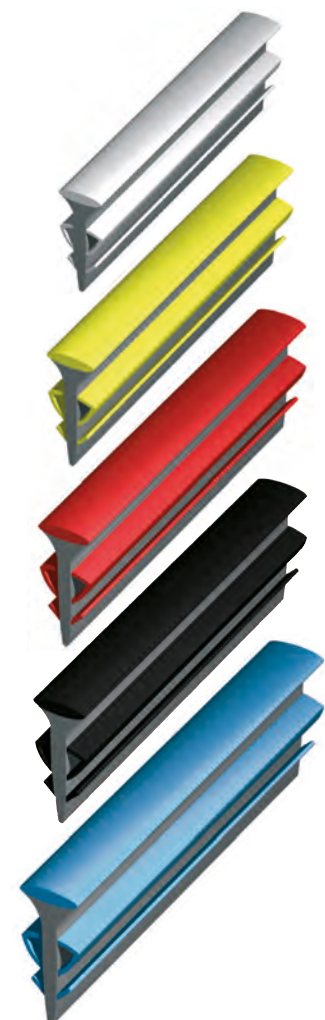

* = Production on demand with minimum quantity of 5000 lm. Production delay 4/5 weeks. Price to be agreed.