

# PAVIJOINT

GREY RIGID PVC

**PAVIJOINT** is a rigid PVC profile with the upper part in elastic PVC/rubber, which absorbs the stress of the floor movements. Two T-irons are inserted inside the profile to strengthen it and to unite two short rods; through holes are also made for the rods 80 cm apart. The **PAVIJOINT** totally replaces the conventional aluminium beams used for shuttering the concrete cast, thereby avoiding demoulding of the cast and cutting of the joint with diamond-slitting disks in a delicate point such as construction joints.

construction joints for industrial floors

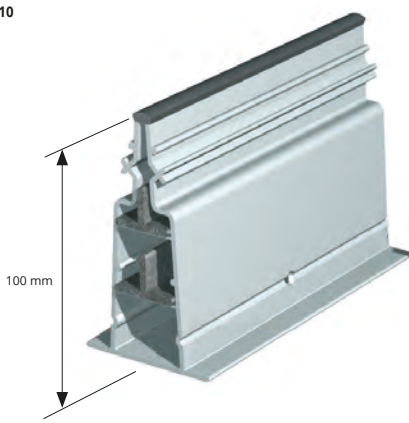

FLOOR TYPE OF LAYING:  
example of laying for heights between 15 and 20 mm

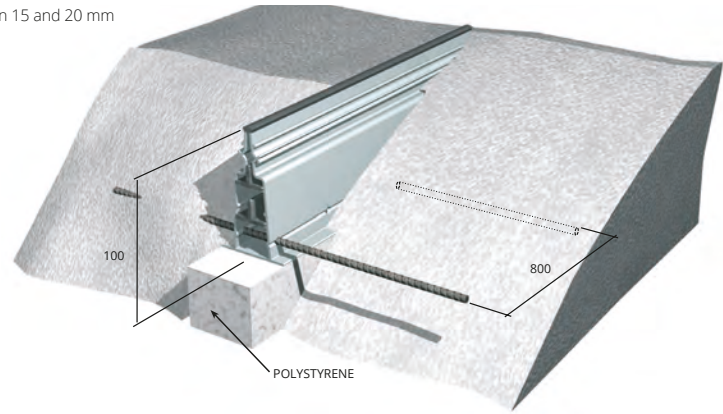

FLOOR SLAB TYPE OF LAYING:  
example of laying for height of 10 mm

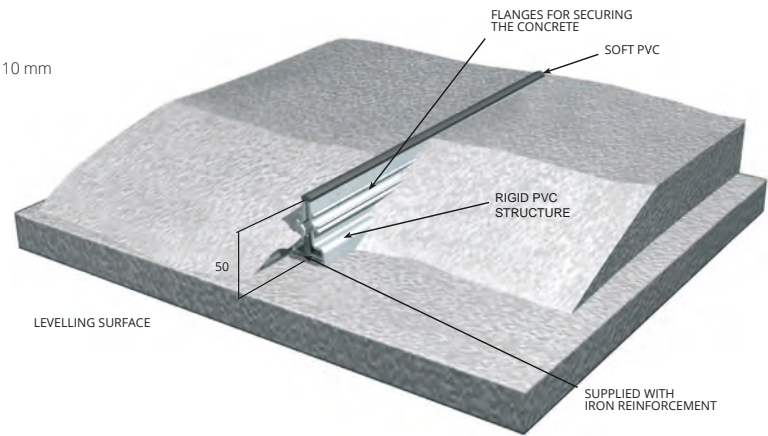

### COMPLETE PAVIJOINT - RIGID VINYL RESIN

bar length **3,10 lm**

Article	H mm		
PVJ 10	100		*

### PHYSICAL-MECHANICAL CHARACTERISTICS OF RIGID PVC

PROPERTIES	U.M.	RESULTS	METHOD
Specific weight	gr/cm <sup>3</sup>	1.45 +/- 0.020	ASTM=D 792
Tensile yield strength	N/mm <sup>2</sup>	49	ASTM=D 638
Ultimate tensile stress	N/mm <sup>2</sup>	44	ASTM=D 638
Ultimate tensile stress	%	4%	ASTM=D 638
Flexural yield strength	N/mm <sup>2</sup>	94	ASTM=D 790
Flexing resistance	N/mm <sup>2</sup>	3240	ASTM=D 790
Impact strength	J/m a 23°C	44	ASTM=D 256
Softening temperature	Vicat°C	83 50N	ASTM=D 1525

### MECHANICAL CHARACTERISTICS OF SOFT PVC/RUBBER

PROPERTIES	U.M.	RESULTS	METHOD
Specific weight	gr/cm <sup>3</sup>	1.25 +/- 0.02	ISO 1183
Hardness	Sh A 15"	67 +/- 2	ISO 868
Ultimate tensile strength	N/mm <sup>2</sup>	> 16	ISO 527
Ultimate elongation	%	> 350	ISO 27

\* = Production on demand with minimum quantity of 100 lm. Production delay 4/5 weeks. Price to be agreed.

## LAYING ACCESSORIES

GREY RIGID PVC



**RIBBED DISTANCE TUBE (to neutralise the short rods)**  
RIGID PVC - bar length 2 lm - pack. 20 Pcs - 50 lm

Article	Ø mm outside		
PPD 20	20		
PPD 22	22		

**PLUGS FOR FINNED TUBE - GREY HD POLYETHYLENE**  
pack. 2000 Pcs divided in two 1000 Pcs bags

Article	Ø mm		
PPT 20	20		
PPT 22	22		

**CORNER JOINTS FOR SECURING PAVIJOINT** - pack. 20 Pcs

Article			
SQBD			*

\* = Production on demand with minimum quantity of 10000 pcs. Production delay 4/5 weeks. Price to be agreed.