

MORTAR LAYING FULL JOINT

CO-EXTRUDED VINYL RESIN (PVC)
WITH FULL SILICONE

FULL SILICONE JOINT is a co-extruded profile in hard and soft PVC. The double internal silicone provides a high degree of resistance to any type of compressive stress, heavy loads and foot traffic. The extension is designed to lengthen the joint, extending it to the total depth of auxiliary or insulation castings as required. Lay the joints according with the standards in force.

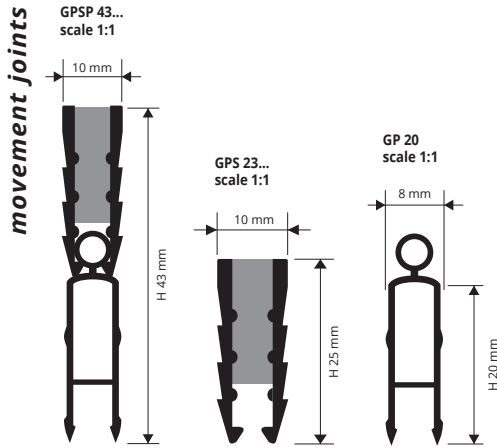

CO-EXTRUDED VINYL RESIN (PVC) WITH FULL SILICONE
bar length 2,5 lm - pack. 40 Pcs - 100 lm

Article	L x H mm	€/lm	€/Pc
GPSP 43...	10 x 43		*
GPS 23...	10 x 25		
GP 20	8 x 20		

COLOURS

GS	GT	GL
Dark grey for rigid and flexible part	Dark grey for rigid part / Transparent for flexible part	Light grey for rigid and flexible part

EXAMPLES AND INSTRUCTIONS FOR LAYING METHODS

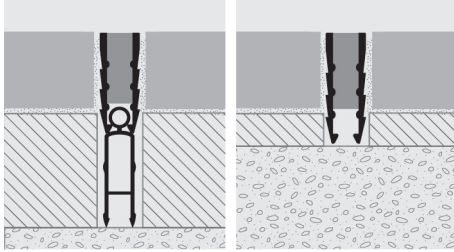

ARTICLES NOT FOR SALE SINGLY

The code of the selected colour must be added to the article code.
E.g.: GPSP 43... (combination chosen colour dark grey/transparent)
GPSP 43GT.

1. Choose the colour and the necessary height of the joint, calculating the thickness of the finished floor and the thickness of the screed.
2. Insert the joint into the screed letting it protrude slightly.
3. Proceed with laying the floor, aligning it with the rigid vertical part of the joint.
4. Complete laying by levelling the joint with the floor.
5. Using the mortar, grout the gap between the tiles and the profile.

PROFLEX 25

NON-TOXIC IMPACT-RESISTANT
CO-EXTRUDED VINYL RESIN

PROFLEX 25 H 25 mm is a new expansion joint made of coextruded vinyl resin available in two standard colours - dark grey (GS) and light grey (GL). **PROFLEX 25 H 25 mm** provides elastic expansion joints for various kinds of flooring, such as marble or granite, and especially floors made with Sasso Italia. The new decorative indoor and outdoor flooring also known as SASSO ITALIA is approx. 25 mm thick and laid over a 10-20 mm base of cement/concrete. This kind of floor needs an expansion/control joint every 16-30 m³ of material to avoid cracking caused by the floor's expansion. PROFLEX H 25 mm lets you place a GP 20 EXTENSION JOINT at the bottom in order to apply/lay the joint inside the concrete base. It can withstand the frequent passage of pedestrians and vehicles (forklifts, pallet trucks, automobiles). The joint must be installed at the same level of the floor or 0.5-1 mm lower (never above). Lay the joints according with the standards in force. **HIGH RESISTANCE TO LOADS AND TO FREQUENT TRAFFIC OF PALLET TRUCKS AND FORKLIFTS.**

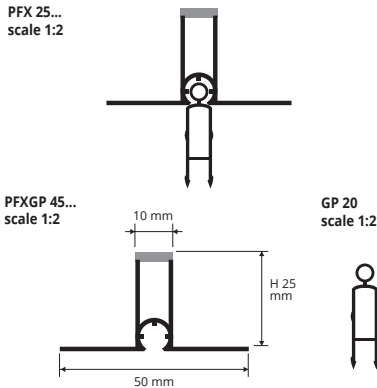

CO-EXTRUDED VINYL RESIN
bar length 2,5 lm - pack. 20 Pcs - 50 lm

Article	H mm	€/lm	€/Pc
PFXGP 45...	45		*
PFX 25...	25		
GP 20	20		

COLOURS

GS	GL
Dark grey for rigid and flexible part	Light grey for rigid and flexible part

EXAMPLES AND INSTRUCTIONS FOR LAYING METHODS

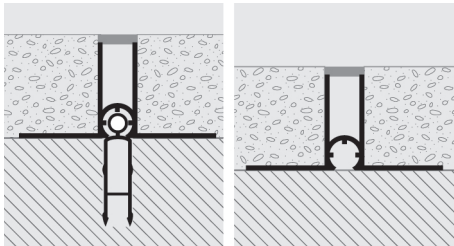

1. Choose the colour of the joint. **1a:** For the version with the extension, insert it onto the fresh cement base leaving the cylindrical part out, for subsequent fitting with PROFLEX 25. **2.** Place and fix with screws/nails to the cement floor and snap the PROFLEX 25 into protruding extension. **3.** Begin laying the floor from the inside, near the joint aligning it with the edges. **4.** Finish laying the floor by levelling the joint with the floor. **5.** Plaster the gap between floor and joint with specific mortar.

The code of the selected colour must be added to the article code.
E.g.: PFX 25 .. (chosen colour dark grey) PFX 25GS.

* = Production on demand with minimum quantity of 100 pcs. Production delay 4/5 weeks. Price to be agreed

Prices are referred to whole packs, 10% increase for minimum orders of 10 Pcs, 20% increase for orders of less than 10 Pcs.