



## MORTAR-LAID DOUBLE JOINT



### DESCRIPTION

**MORTAR-LAID DOUBLE JOINT** is an expansion joint composed of a structure in non-toxic vinyl resin and a double expandable part in soft vinyl resin. Its design ensures effective anchorage to the screed, preventing its extraction.

### MATERIAL

**MORTAR-LAID DOUBLE JOINT** is an expansion joint composed of a structure in non-toxic vinyl resin with a height of 23 mm, and a double expandable part, in soft vinyl, with a visible surface of 10 mm. The structure in non-toxic vinyl resin has a serrated surface that ensures effective anchorage to the screed preventing its extraction. The joint is completed with an extension, in non-toxic vinyl resin, 20 mm long. The double expandable part, in soft vinyl resin, is resistant to fungus, bacteria and UV rays.

### AREAS OF USE

**MORTAR-LAID DOUBLE JOINT** in co-extruded vinyl resin is suitable in environments with light traffic.

### WARNINGS

Do not use **MORTAR-LAID DOUBLE JOINT** in co-extruded vinyl resin in environments subject to heavy traffic.

### MAINTENANCE

**MORTAR-LAID DOUBLE JOINT** does not require any special maintenance. It is suggested to clean it with normal household cleaning products.

### LAYING INSTRUCTIONS

1. Choose "**MORTAR-LAID DOUBLE JOINT**" according to the height and desired colour.
2. Cut "**MORTAR-LAID DOUBLE JOINT**" to the desired length.
3. Cut with a trowel the fresh screed following the floor edges.
4. Apply the joint inside the fresh screed taking care to align it with the surface of the floor.
5. Proceed with laying the screed and flooring.

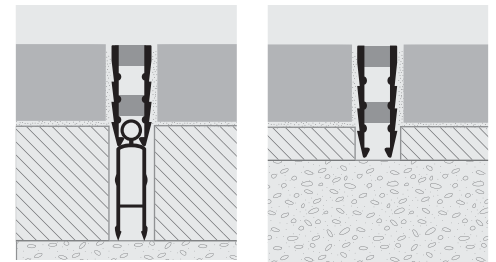
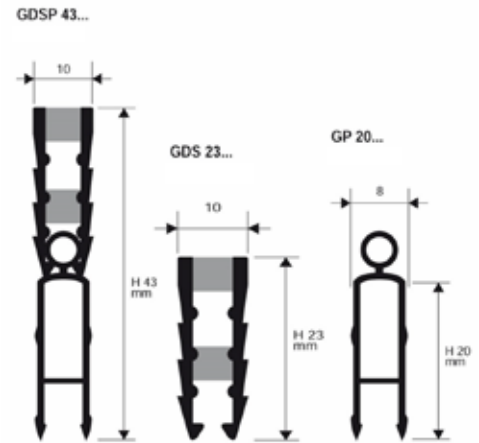

### TEXT TEMPLATE FOR TENDERS

Delivery and installation of expansion joint composed of a structure in non-toxic vinyl resin, with a height of 23 mm and a double expandable part, in soft vinyl, with a visible surface of 10 mm. The structure in non-toxic vinyl resin has a serrated surface, that ensures effective anchorage to the screed preventing its extraction. The joint is completed with an extension, in non-toxic vinyl resin, 20 mm long. The double expandable part, in soft vinyl resin, is resistant to fungus, bacteria and UV rays, like **MORTAR-LAID DOUBLE JOINT** of the Progress Profiles company.

**GDSP 43...** : Non-toxic vinyl resin expansion joint + non-toxic vinyl resin extension.

**GDS 23...** : Non-toxic vinyl resin expansion joint.

**GP 20** : Non-toxic vinyl resin extension.

Profile height : \_\_\_\_\_ mm

Profile length : \_\_\_\_\_ mt

Material : \_\_\_\_\_ €/mt

Application : \_\_\_\_\_ €/mt

Total value : \_\_\_\_\_ €/mt